

# 5716PIA-FW High range Piano Sound module

## Firmware for SAM5716

### Signal Processing Synoptic

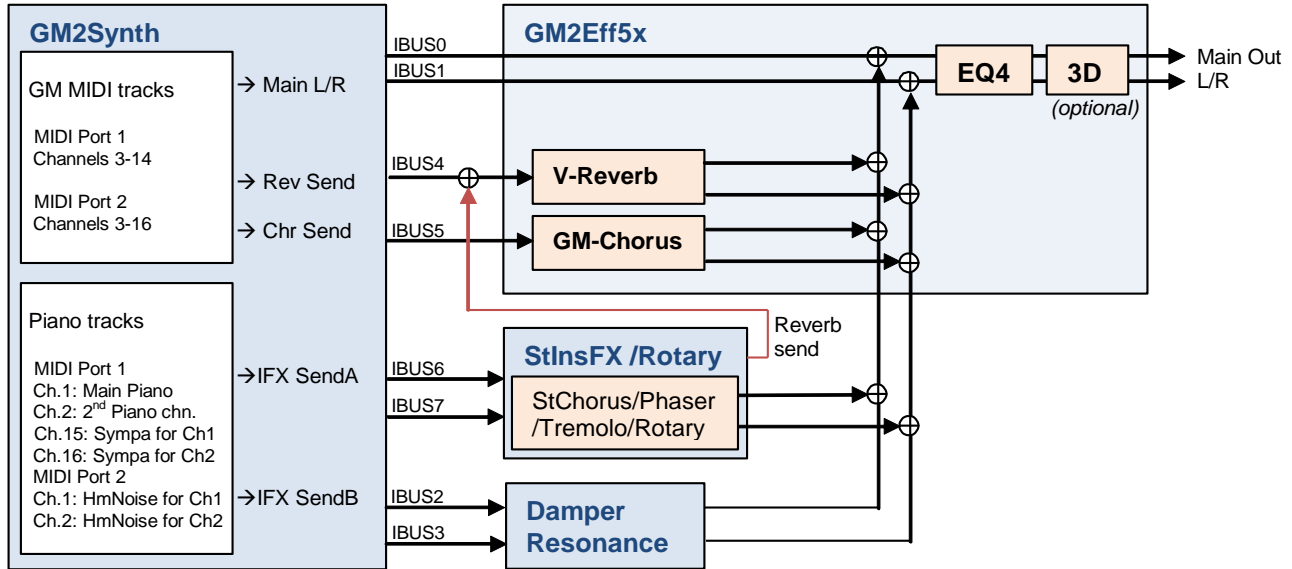

Note: shown here is the “parallel” configuration of Insert FX and Damper Resonance effect (see description for NRPN 3750h).

### DSP configuration

- “GM2Synth” Synthesizer, 256 voice polyphony (11 DSPs)
- “GM2Eff5x” V-Reverb + GM-Chorus + 4 bands EQ (1 DSP)
- “StInsEff” Stereo Chorus/Phaser/Tremolo Insert Effect or “Rotary” Effect (1 DSP)
- Sympathetic Damper Resonance Effect (1 DSP)
- 2 DSPs free for other functions (e.g. Microphone input & effects, USB Audio)

### Hardware configuration

- SAM5716 + NAND/NOR Flash + SDRAM/SRAM + stereo DAC
- 44.1KHz or 48KHz sampling rate

This publication neither states nor implies any warranty of any kind, including, but not limited to, implied warrants of merchantability or fitness for a particular application. Dream assumes no responsibility for the use of any circuitry. No circuit patent licenses are implied.

The information in this publication is believed to be accurate in all respects at the time of publication but is subject to change without notice. Dream assumes no responsibility for errors and omissions, and disclaims responsibility for any consequences resulting from the information included herein.

## Special Piano Controls

### Piano Controls on MIDI Channel 1

Additional functions on MIDI channel 1 (Main Piano track) to what is described in MIDI implementation chart (page 4).

MIDI Message	HEX Code	Description	Default
NOTE ON	90h kk vv	Trigger sympathetic string resonance harmonics	-
NOTE OFF	80h kk vv	Release sympathetic string resonance harmonics	-
CTRL 64	B0h 40h cc	Sustain pedal, activate Damper Resonance Effect. “cc” values in range 0..127, Half Pedal feature supported.	-
CTRL 74	B0h 4Ah cc	Brightness 0 = -6dB ... 64 = 0dB ... 127 = +6dB	64
CTRL 80	B0h 50h cc	Reverb Preset (0.4 = OFF, Room1, Room2, Hall, Stage)	2
CTRL 81	B0h 51h cc	FX Preset (0.4 = OFF, Chorus, Phaser, Tremolo, Rotary)	1
CTRL 82	B0h 52h cc	Rotary control (0..63 = slow, 64 = brake, 65..127 = fast)	slow
CTRL 91	B0h 5Bh cc	Reverb send level (0..127)	64
CTRL 93	B0h 5Dh cc	FX send level / depth (0..127)	0

### DREAM Special NRPN Controls

MIDI channel must be 1 (port 1) for all these NRPNs.

NRPN sending method:

CTRL#99=high byte, CTRL#98=low byte, CTRL#6=vv

Example:

In order to set General Master Volume (NRPN 3707h) to value 64 (40h), send

- CTRL#99=55 (37h) (MIDI hex code: B0h 63h 37h)
- CTRL#98=07 (07h) (MIDI hex code: B0h 62h 07h)
- CTRL#6 =64 (40h) (MIDI hex code: B0h 06h 40h)

NRPN # (High Low)	Description	Power-up default
<b>Piano Pedal/Hammer Noise Controls</b>		
0101h	Pedal Noise Level (0..127)	0
0102h	Damper Pedal String Level (0..127)	0
0103h	Hammer Noise Level (0..127)	0
<b>Damper Resonance Effect Controls</b>		
0200h	Damper Resonance Level (0..127)	100
0201h	Damper Resonance Response (Fade-In/Out time, 0..15 = 20µs..0.66s)	12=80ms
0202h	Pre-Low-Pass Filter Frequency (0=cut freq at ~2KHz, till 127=filter full open)	127
0203h	Pre-High-Pass Filter Frequency (0=no filtering, till 127=cut freq at ~1KHz)	10
0204h	Reverberation Time (0..127)	64
0205h	Reverberation Hi-Damp (0..127)	64
0206h	Post-High-Shelf Filter Gain (0=-12dB, 64=0dB, 127=+6dB)	100
0207h	Post-High-Shelf Filter Freq (0..127, ~800Hz to 3KHz)	0
0208h	Sympathetic String Resonance On/Off	ON
0209h	Sympathetic String Resonance Level	30
020Ah	Minimum Damper Resonance Level (note 1)	
020Bh	Max Pre-High-Pass Filter Frequency (note 1)	
020Ch	Minimum Reverberation Time (note 1)	

Note 1 : these values are used when Damper Pedal is OFF (depressed)

Reverb Effect Controls		
0300h	Reverb Level (0..127)	64
0301h	Pre-Delay Time (0 = 0ms, till 127 = 250ms)	0
0302h	Reverberation Time (0..127)	64
0303h	Pre-Low-Pass Filter Frequency (0=filter open, till 7=filter closed)	0
0304h	Pre-High-Pass Filter Frequency (0..127)	0
0305h	Post-High-Shelf Filter Gain (0=-12dB...64=0dB...127=+6dB)	64
0306h	Room Size (0=largest, till 2=smallest)	0
0307h	Reverb Type (0..2=room, 3..4=hall, 5=plate)	4
Chorus/Phaser/Tremolo Effect Controls		
0400h	Effect Level	64
0401h	Chorus/Flanging Delay Time (0 = 1ms, till 127 = 10.6ms)	*
0402h	Chorus Feedback (0..127)	*
0403h	Pre-Low-Pass Filter (0..127, 127=no filtering)	127
0407h	Modulation Effect Type: 0=Chorus, 2=Tremolo, 3=Phaser	*
0408h	Modulation Rate: 0 = ~0,023 Hz, ...64=~0,89Hz, till 127 = ~5,8 Hz	*
0409h	Modulation Depth (0..127)	*
040Ah	Tremolo Shape (0=triangle, till 127=rectangle, only for Tremolo type)	*
4-bands EQ Controls		
3708h	Equalizer Low Band Gain	0=-12dB, 64=0dB, 127=+12dB
3709h	Equalizer Low Mid Band Gain	0=-12dB, 64=0dB, 127=+12dB
370Ah	Equalizer High Mid Band Gain	0=-12dB, 64=0dB, 127=+12dB
370Bh	Equalizer High Band Gain	0=-12dB, 64=0dB, 127=+12dB
370Ch	Equalizer Low Band Freq	0=40Hz, 64=550Hz, 127=1060Hz
370Dh	Equalizer Low Mid Band Freq	0=60Hz, 64=4.1KHz, 127=8.2kHz
370Eh	Equalizer High Mid Band Freq	0=60Hz, 64=4.1KHz, 127=8.2kHz
370Fh	Equalizer High Band Freq	0=1kHz, 64=3KHz, 127=5.1kHz
3710h	Equalizer Low Mid Band Q	0:Q=1, 64:Q=2, 127:Q=20
3711h	Equalizer High Mid Band Q	0:Q=1, 64:Q=2, 127:Q=20
Spatializer 3D Effect (optionally)		
371Ch	Spatializer effect volume	0=no effect, till 127=maximum effect
371Dh	Spatializer effect delay time	0=0ms, till 127=max delay time
371Eh	Spatializer effect input mode	0=stereo, else mono
General		
3707h	Synthesizer Master volume	0 (mute) to 7Fh (max)
3750h	Set Piano track 2 routing value = 0 -> chained routing: Damper Resonance -> Insert FX (default) value = 1 -> parallel routing: Piano track 1 -> Damper Reso, track 2 -> Insert FX	0
3751h	Auto-Test	-
3755h	EQ / 3D Effect ON/OFF	bit 0: 0=EQ OFF, 1=EQ ON bit 2: 0=3D OFF, 1=3D ON

## Detailed MIDI Implementation

2 ports of 16 channels are provided for a total of 32 channels. MIDI Message “F5 nn” is used to switch between the two ports (nn=1 or 2).

MIDI Message	HEX Code	Description	Compatibility
NOTE ON	9nH kk vv	Midi channel n(0-15) note ON #kk(1-127), velocity vv(1-127). vv=0 means NOTE OFF	MIDI
NOTE OFF	8nH kk vv	Midi channel n(0-15) note OFF #kk(1-127), vv is don't care.	MIDI
PITCH BEND	EnH bl bh	Pitch bend as specified by bh bl (14 bits) Maximum swing is +/- 1 tone (power-up). Can be changed using « pitch bend sensitivity ». Center position is 00H 40H.	GM
PROGRAM CHANGE	CnH pp	Program (patch) change. Specific action on channel 10 (n=9) : select drumset. Refer to sounds / drumset list. Drumsets can be assigned to other channels (see SYSEX MIDI channel to part assign and part to rhythm allocation)	GM/GS
CHANNEL AFTERTOUCH	DnH vv	vv pressure value. Effect set using Sys. Ex. 40H 2pH 20H-26H	MIDI
CTRL 00	BnH 00H cc	Bank select : Refer to sounds list. No action on drumset	GS/ DREAM
CTRL 01	BnH 01H cc	Modulation wheel. Rate and maximum depth can be set using SYSEX	MIDI
CTRL 05	BnH 05H cc	Portamento time.	MIDI
CTRL 06	BnH 06H cc	Data entry : provides data to RPN and NRPN	MIDI
CTRL 07	BnH 07H cc	Volume (default=100)	MIDI
CTRL 10	BnH 0AH cc	Pan (default=64 center)	MIDI
CTRL 11	BnH 0BH cc	Expression (default=127)	MIDI/GM
CTRL 64	BnH 40H cc	Sustain (damper) pedal	MIDI
CTRL 65	BnH 41H cc	Portamento ON/OFF	MIDI
CTRL 66	BnH 42H cc	Sostenuto pedal	MIDI
CTRL 67	BnH 43H cc	Soft pedal	MIDI
CTRL 71	BnH 47H cc	TVF Resonance modify (same as nrpn 0121h)	GM/GS
CTRL 72	BnH 48H cc	Env release time modify (same as nrpn 0166h)	GM/GS
CTRL 73	BnH 49H cc	Env attack time modify (same as nrpn 0163h)	GM/GS
CTRL 74	BnH 4AH cc	TVF cutoff freq modify (same as nrpn 0120h)	GM/GS
CTRL 75	BnH 4BH cc	Env decay time modify (same as nrpn 0164h)	GM/GS
CTRL 76	BnH 4CH cc	Vibrato rate modify (same as nrpn 0108h)	GM/GS
CTRL 77	BnH 4DH cc	Vibrato depth modify (same as nrpn 0109h)	GM/GS
CTRL 78	BnH 4EH cc	Vibrato delay modify (same as nrpn 010Ah)	GM/GS
CTRL 84	BnH 54H vv	Portamento control	GS
CTRL 91	BnH 5BH vv	Reverb send level vv=00H to 7FH	GS
CTRL 93	BnH 5DH vv	Chorus send level vv=00H to 7FH	GS
CTRL 98	BnH 62H vv	NRPN low	MIDI
CTRL 99	BnH 63H vv	NRPN high	MIDI
CTRL 100	BnH 64H vv	RPN low	MIDI
CTRL 101	BnH 65H vv	RPN high	MIDI
CTRL 120	BnH 78H 00H	All sound off (abrupt stop of sound on channel n)	MIDI
CTRL 121	BnH 79H 00H	Reset all controllers	MIDI
CTRL 123	BnH 7BH 00H	All notes off	MIDI
CTRL 126	BnH 7EH 00H	Mono on	MIDI
CTRL 127	BnH 7FH 00H	Poly on (default power-up)	MIDI

CTRL CC1	BnH ccH vvH	Assignable Controller 1. cc=Controller number (0-5Fh), vv=Control value (0-7Fh). Control number (ccH) can be set on CC1 CONTROLLER NUMBER (Sys. Ex 40 1x 1F). The resulting effect is determined by CC1 controller function (Sys.Ex. 40 2p 40-4A)	GS
CTRL CC2	BnH ccH vvH	Assignable Controller 2. cc=Controller number (00h-5Fh), vv=control value (0-7Fh). Control number can be set on CC2 CONTROLLER NUMBER (Sys.Ex. 40 1x 20). The resulting effect is determined by CC2 controller function (Sys.Ex.40 2p 50-5A).	GS
RPN 0000H	BnH 65H 00H 64H 00H 06H vv	Pitch bend sensitivity in semitones (default=2)	MIDI/GM
RPN 0001H	BnH 65H 00H 64H 01H 06H vv	Fine tuning in cents (vv=00 -100, vv=40H 0, vv=7FH +100)	MIDI
RPN 0002H	BnH 65H 00H 64H 02H 06H vv	Coarse tuning in half-tones (vv=00 -64, vv=40H 0, vv=7FH +64)	MIDI
NRPN 0108H	BnH 63H 01H 62H 08H 06H vv	Vibrate rate modify (vv=40H -> no modif)	GS
NRPN 0109H	BnH 63H 01H 62H 09H 06H vv	Vibrate depth modify (vv=40H -> no modif)	GS
NRPN 010AH	BnN 63H 01H 62H 0AH 06H vv	Vibrate delay modify (vv=40H -> no modif)	GS
NRPN 0120H	Bnh 63H 01H 62H 20H 06H vv	TVF cutoff freq modify(vv=40H -> no modif)	GS
NRPN 0121H	BnH 63H 01H 62H 21H 06H vv	TVF resonance modify (vv=40H -> no modif)	GS
NRPN 0163H	Bnh 63H 01H 62H 63H 06H vv	Env. attack time modify(vv=40H ->no modif)	GS
NRPN 0164H	BnH 63H 01H 62H 64H 06H vv	Env. decay time modify(vv=40H -> no modif)	GS
NRPN 0166H	BnH 63H 01H 62H 66H 06H vv	Env. release time modif(vv=40H ->no modif)	GS
NRPN 18rrH	BnH 63H 18H 62H rr 06H vv	Pitch coarse of drum instr. note rr in semitones (vv=40H -> no modif) (note 6)	GS
NRPN 1ArrH	BnH 63H 1AH 62H rr 06H vv	Level of drum instrument note rr (vv=00 to 7FH) (note 6)	GS
NRPN 1BrrH	BnH 63H 1BH 62H rr 06H vv	Front/Rear mix of drum instrument note rr (vv=00 to 7FH) (note 6)	DREAM
NRPN 1CrrH	BnH 63H 1CH 62H rr 06H vv	Pan of drum instrument note rr (40H = middle) (note 6)	GS
NRPN 1DrrH	BnH 63H 1DH 62H rr 06H vv	Reverb send level of drum instrument note rr (vv=00 to 7FH) (note 6)	GS
NRPN 1ErrH	BnH 63H 1EH 62H rr 06H vv	Chorus send level of drum instrument note rr (vv=00 to 7FH) (note 6)	GS
Standard Sysex	FOH 7EH 7FH 09H 01H F7H	General MIDI reset (note 4)	GM
Standard Sysex	FOH 7FH 7FH 04H 01H 00H ll F7H	Master volume (ll=0 to 127, default 127) (note 4). Not reset by GS reset	GM
SYSEX	F0h 00h 20h 00h 00h 00h...	Tuning System Exclusive message (see page 3)	DREAM
SYSEX	FOH 41H 00H 42H 12H 40H 00H 00H dd dd dd dd xx F7H	Master tune (default dd= 00H 04H 00H 00H) -100.0 to +100.0 cents. Nibblized data should be used (always four bytes). For example, to tune to +100.0 cents, sent data should be 00H 07H 0EH 08H (note 4)	GS
SYSEX	FOH 41H 00H 42H 12H 40H 00H 04H vv xx F7H	Master volume (default vv=7FH) (note 4) Not reset by GS reset.	GS
SYSEX	FOH 41H 00H 42H 12H 40H 00H 05H vv xx F7H	Master key-shift (default vv=40H, no transpose) (note 4)	GS
SYSEX	FOH 41H 00H 42H 12H 40H 00H 06H vv xx F7H	Master pan (default vv=40H, center) (note 4)	
SYSEX	FOH 41H 00H 42H 12H 40H 00H 7FH 00H xx F7H	GS reset (note 4)	GS
SYSEX	FOH 41H 00H 42H 12H 40 01H 10H vv1 vv2 vv3 vv4 vv5 vv6 vv7 vv8 vv9 vv10 vv11 vv12 vv13 vv14 vv15 vv16 xx F7h	Voice reserve : vv1= Part 10 (Default vv=2) vv2 to vv10 = Part 1 to 9 (Default vv=2) vv11 to vv16= Part 11 to 16 (Default vv=0) (note 4)	GS

SYSEX	FOH 41H 00H 42H 12H 40H 01H 30H vv xx F7H	Reverb type (vv=0 to 7), default = 04H  00H : Room1                      01H : Room2 02H : Room3                      03H : Hall1 04H : Hall2                        05H : Plate 06H : Delay                        07H : Pan delay  (note 5)	GS
SYSEX	FOH 41H 00H 42H 12H 40H 01H 31H vv xx F7H	Reverb character, default 04H (note 5)	GS
SYSEX	FOH 41H 00H 42H 12H 40H 01H 32H vv xx F7H	Reverb Pre-LPF, 0 to 7, default 0 (note 5)	GS
SYSEX	FOH 41H 00H 42H 12H 40H 01H 33H vv xx F7H	Reverb master level, default = 64 (note 5)	GS
SYSEX	FOH 41H 00H 42H 12H 40H 01H 34H vv xx F7H	Reverb time (note 5)	GS
SYSEX	FOH 41H 00H 42H 12H 40H 01H 35H vv xx F7H	Reverb delay feedback. Only if reverb number=6 or 7 (delays) (note 5)	GS
SYSEX	FOH 41H 00H 42H 12H 40H 01H 37H vv xx F7H	Reverb pre delay time (vv=0 to 7Fh = 0ms to 127ms). Only if reverb number=0 to 5 (reverbs)	GS
SYSEX	FOH 41H 00H 42H 12H 40H 01H 38H vv xx F7H	Chorus type (vv=0 to 7), default = 02H  00H : Chorus1                      01H : Chorus2 02H : Chorus3                      03H : Chorus4 04H : Feedback                      05H : Flanger 06H : Short delay                      07H : FB delay  (note 5)	GS
SYSEX	FOH 41H 00H 42H 12H 40H 01H 39H vv xx F7H	Chorus Pre-LPF, 0 to 7, default = 0 (note 5)	GS
SYSEX	FOH 41H 00H 42H 12H 40H 01H 3AH vv xx F7H	Chorus master level, default = 64 (note 5)	GS
SYSEX	FOH 41H 00H 42H 12H 40H 01H 3BH vv xx F7H	Chorus feedback (note 5)	GS
SYSEX	FOH 41H 00H 42H 12H 40H 01H 3CH vv xx F7H	Chorus delay (note 5)	GS
SYSEX	FOH 41H 00H 42H 12H 40H 01H 3DH vv xx F7H	Chorus rate (note 5)	GS
SYSEX	FOH 41H 00H 42H 12H 40H 01H 3EH vv xx F7H	Chorus depth (note 5)	GS
SYSEX	FOH 41H 00H 42H 12H 40H 01H 3FH vv xx F7H	Chorus send level to reverb, default=0 (note 5)	GS
SYSEX	FOH 41H 00H 42H 12H 40H 02H 00H vv xx F7H	EQ Low Freq, vv: 0=200Hz, 1=400Hz, default 0	GS
SYSEX	FOH 41H 00H 42H 12H 40H 02H 01H vv xx F7H	EQ Low Gain, vv: 0=-12dB, 40h=0dB, to7Fh=+12dB, default 60h=+6dB	GS
SYSEX	FOH 41H 00H 42H 12H 40H 02H 02H vv xx F7H	EQ High Freq, vv: 0=3KHz, 1=6KHz, default 0	GS
SYSEX	FOH 41H 00H 42H 12H 40H 02H 03H vv xx F7H	EQ High Gain, vv: 0=-12dB, 40h=0dB, to7Fh=+12dB, default 60h=+6dB	GS
SYSEX	FOH 41H 00H 42H 12H 40H 1pH 02H nn xx F7H	MIDI channel to part assign, p is part (0 to 15), nn is MIDI channel (0 to 15, 16=OFF). This SYSEX allows to assign several parts to a single MIDI channel or to mute a part. (note 3) Default assignment : <u>part</u> <u>MIDI channel</u> 0            9            (DRUMS) 1-9        0-8 10-15     10-15	GS

SYSEX	F0H 41H 00H 42H 12H 40H 1pH 15H vv xx F7H	Part to rhythm allocation, p is part (0 to 15), vv is 00 (sound part) or 01 (rhythm part). This SYSEX allows a part to play sound or drumset. There is no limitation of the number of parts playing drumset. Default assignment : part 0 plays drums (default MIDI channel 9) all other parts play sound. (note 3)	GS
SYSEX	F0H 41H 00H 42H 12H 40H 1pH 40H v1 v2 ... v12 xx F7H	Scale tuning, p is part (0 to 15), v1 to v12 are 12 semi-tones tuning values (C, C#, D, ... A#, B), in the range -64 (00H) 0 (40H) +63(7FH) cents. This SYSEX allows non chromatic tuning of the musical scale on a given part. Default v1, v2, ... ,v12 = 40H, 40H,...,40H (chromatic tuning). Scale tuning has no effect if the part is assigned to a rhythm channel or if the sound played is not of chromatic type. (note 3)	GS
SYSEX	F0H 41H 00H 42H 12H 40H 1pH 1AH vv xx F7H	Velocity slope from 00H to 7FH (default = 40H) (note 3)	GS
SYSEX	F0H 41H 00H 42H 12H 40H 1pH 1BH vv xx F7H	Velocity offset from 00H to 7FH (default = 40H) (note 3)	GS
SYSEX	F0H 41H 00H 42H 12H 40H 1pH 1FH vv xx F7H	CC1 Controller number (00-5FH) (default = 10H) (note 3)	GS
SYSEX	F0H 41H 00H 42H 12H 40H 1pH 20H vv xx F7H	CC2 Controller number (00-5FH) (default = 11H) (note 3)	GS
SYSEX	F0H 41H 00H 42H 12H 40H 2pH 00H vv xx F7H	Mod pitch control (-24,+24 semitone) (default = 40H) (note 3)	GS
SYSEX	F0H 41H 00H 42H 12H 40H 2pH 01H vv xx F7H	Mod tvf cutoff control (default = 40H) (note 3)	GS
SYSEX	F0H 41H 00H 42H 12H 40H 2pH 02H vv xx F7H	Mod Amplitude control (-100%+100%) (default=40H) (note 3)	GS
SYSEX	F0H 41H 00H 42H 12H 40H 2pH 03H vv xx F7H	Mod lfo1 rate control (default = 40H). n is don't care. Rate is common on all channels	GS
SYSEX	F0H 41H 00H 42H 12H 40H 2pH 04H vv xx F7H	Mod lfo1 pitch depth (0-600 cents) (default=0AH) (note 3)	GS
SYSEX	F0H 41H 00H 42H 12H 40H 2pH 05H vv xx F7H	Mod lfo1 tvf depth (default = 0H) (note 3)	GS
SYSEX	F0H 41H 00H 42H 12H 40H 2pH 06H vv xx F7H	Mod lfo1 tva depth (0-100%) (default = 0H) (note 3)	GS
SYSEX	F0H 41H 00H 42H 12H 40H 2pH 10H vv xx F7H	Bend pitch control (-24,+24 semitone) (default = 42H) (note 3)	GS
SYSEX	F0H 41H 00H 42H 12H 40H 2pH 11H vv xx F7H	Bend tvf cutoff control (default = 40H) (note 3)	GS
SYSEX	F0H 41H 00H 42H 12H 40H 2pH 12H vv xx F7H	Bend Amplitude control (-100%+100%) (default=40H) (note 3)	GS
SYSEX	F0H 41H 00H 42H 12H 40H 2pH 14H vv xx F7H	Bend lfo1 pitch depth (0-600 cents) (default=00H) (note 3)	GS
SYSEX	F0H 41H 00H 42H 12H 40H 2pH 15H vv xx F7H	Bend lfo1 tvf depth (default = 0H) (note 3)	GS
SYSEX	F0H 41H 00H 42H 12H 40H 2pH 16H vv xx F7H	Bend lfo1 tva depth (0-100%) (default = 0H) (note 3)	GS
SYSEX	F0H 41H 00H 42H 12H 40H 2pH 20H vv xx F7H	CAF pitch control (-24,+24 semitone) (default = 40H) (note 3)	GS
SYSEX	F0H 41H 00H 42H 12H 40H 2pH 21H vv xx F7H	CAF tvf cutoff control (default = 40H) (note 3)	GS
SYSEX	F0H 41H 00H 42H 12H 40H 2pH 22H vv xx F7H	CAF Amplitude control (-100%+100%) (default=40H) (note 3)	GS

SYSEX	F0H 41H 00H 42H 12H 40H 2pH 24H vv xx F7H	CAF lfo1 pitch depth (0-600 cents) (default=00H) (note 3)	GS
SYSEX	F0H 41H 00H 42H 12H 40H 2pH 25H vv xx F7H	CAF lfo1 tvf depth (default = 0H) (note 3)	GS
SYSEX	F0H 41H 00H 42H 12H 40H 2pH 26H vv xx F7H	CAF lfo1 tva depth (0-100%) (default = 0H) (note 3)	GS
SYSEX	F0H 41H 00H 42H 12H 40H 2pH 40H vv xx F7H	CC1 pitch control (-24,+24 semitone) (default = 40H) (note 3)	GS
SYSEX	F0H 41H 00H 42H 12H 40H 2pH 41H vv xx F7H	CC1 tvf cutoff control (default = 40H) (note 3)	GS
SYSEX	F0H 41H 00H 42H 12H 40H 2pH 42H vv xx F7H	CC1 Amplitude control (-100%+100%) (default=40H) (note 3)	GS
SYSEX	F0H 41H 00H 42H 12H 40H 2pH 44H vv xx F7H	CC1 lfo1 pitch depth (0-600 cents) (default=00H) (note 3)	GS
SYSEX	F0H 41H 00H 42H 12H 40H 2pH 45H vv xx F7H	CC1 lfo1 tvf depth (default = 0H) (note 3)	GS
SYSEX	F0H 41H 00H 42H 12H 40H 2pH 46H vv xx F7H	CC1 lfo1 tva depth (0-100%) (default = 0H) (note 3)	GS
SYSEX	F0H 41H 00H 42H 12H 40H 2pH 50H vv xx F7H	CC2 pitch control (-24,+24 semitone) (default = 40H) (note 3)	GS
SYSEX	F0H 41H 00H 42H 12H 40H 2pH 51H vv xx F7H	CC2 tvf cutoff control (default = 40H) (note 3)	GS
SYSEX	F0H 41H 00H 42H 12H 40H 2pH 52H vv xx F7H	CC2 Amplitude control (-100%+100%) (default=40H) (note 3)	GS
SYSEX	F0H 41H 00H 42H 12H 40H 2pH 54H vv xx F7H	CC2 lfo1 pitch depth (0-600 cents) (default=00H) (note 3)	GS
SYSEX	F0H 41H 00H 42H 12H 40H 2pH 55H vv xx F7H	CC2 lfo1 tvf depth (default = 0H) (note 3)	GS
SYSEX	F0H 41H 00H 42H 12H 40H 2pH 56H vv xx F7H	CC2 lfo1 tva depth (0-100%) (default = 0H) (note 3)	GS
SYSEX	F0H 41H 00H 42H 12H 40H 4pH 22H nn xx F7H	with 'p'=MIDI track, 'nn': 0 = track in normal mode, 1 = send to MFX1, 2 = send to MFX2, 3 = send to both MFX	GS / DREAM

- Notes :**
1. NRPN sending method : CTRL#99=high byte, CTRL#98=low byte, CTRL#6=vv. Example : NRPN 0108h = 40h -> CTRL#99=1, CTRL#98=8, CTRL#6=64.
  2. x or xx means « don't care »
  3. Cross system exclusive :  
Address can be 040h xxh xxh or 050h xxh xxh  
If addresse=040h xxh xxh : system exclusive applies to midi port 1 (midi channels 0-Fh) if received on midi port1 , applies to midi port 2 (midi channels 10-1Fh) if received on midi port 2.  
If addresse=050h xxh xxh, cross system exclusive : applies to port 2 if received on port1, applies to port 1 if received on port2
  4. Non cross system exclusive applying only on receiving port :  
System exclusive applies to midi port 1 (midi channels 0-Fh) if received on midi port1.  
System exclusive applied to midi port 2 (midi channels 10-1Fh) if received on midi port2.
  5. Non cross system exclusive applying on both ports :  
System exclusive will be applied to all midi channels (0-1Fh). Can be received on port 1 or port 2 indifferently.  
This is the case for all system exclusive concerning reverb and chorus because reverb and chorus are the same for both ports 1 and 2.
  6. Drumset edit Nrpn : 4 different drumset edit tables are implemented :
    - 1 for midi port 1 channel 10
    - 1 for midi port 2 channel 10
    - 1 for midi port 1 channels 1-9 or 11-16 : for all these channels, edit table is the same
    - 1 for midi port 2 channels 1-9 or 11-16 : for all these channels, edit table is the same